

HMWDZVLZHUMDOHMVNDGDVLC :

GDSURTOHEREP

GKRSURTOKEFWUDOHRPP

DISURTOHEREPHMWDISURMENWRDHWDNIDEIMKDIMIGRIURGNDISURTOKTHHOK

DSHCHDSUHGX*HCDPPGRPPWAMVDPHMVPR*DRMVC

GODHWDKWWDUFDPWRDDIHMPRGHOHFWODWRUY*

*FDHOFREIRGPRGHOKVWHPK66

8PLHRENVLHEHMSRERNDKWDVTRUPDWRUD66

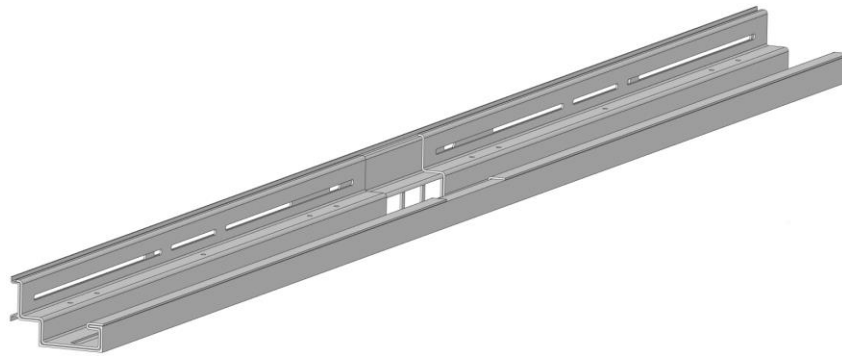

8Y*MXISRGWWDWUDVTRUPDWRUDITURGNKMSRR*H*H*DMEURGNRHMNRKPC

WUDVTRUPDWRUDMDNRSKNWKRGLHVDI

NUFETOKEFORNKMEHIMORGEHSTOINISREMDISREWNRDIMMUDLH

SRWUHEBUHVX6SURTOHEREPGR*GDARPIDUXUKEFORNKMEHDK*

GRPRERDIDMDEGDAMIGKREILPKVER*RHGSRCHGLH

RWRURUHGLEPPI

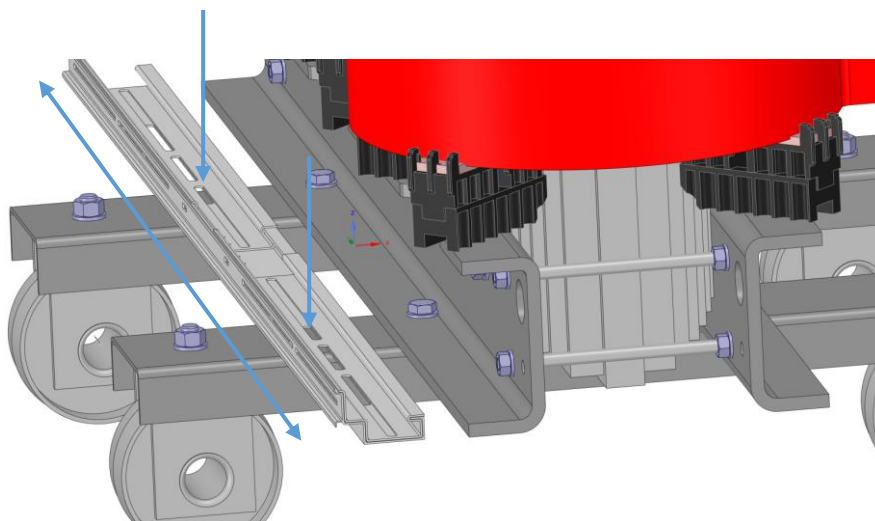

DPREKMWK6RGWWDWUDVTRUPDWRUDDSRPREVSHEMDOEKWRUYPREKMEEK

VKHURDEHUKED6RGNDGNI

8Y*UKFEFORNKMEHRED6SURTOHURGNRTEREDYNKWUDVTRUPDWRUDI

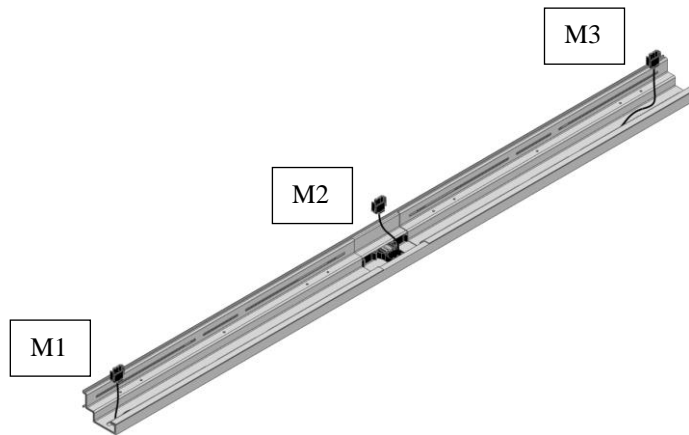

Conveniently position the wiring for the fans, M1-M2-M3. Reposition the excess wiring in the appropriate housing by stopping the cables again. Connect the power cord to each installed fan.

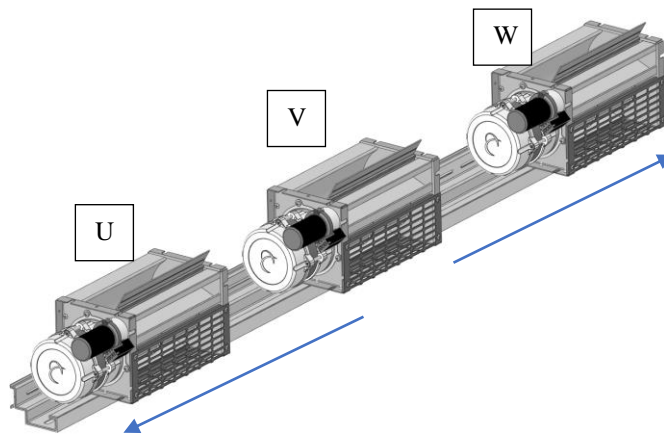

Place the fans on the bar, center each individual fan with the reference column U-V-W.

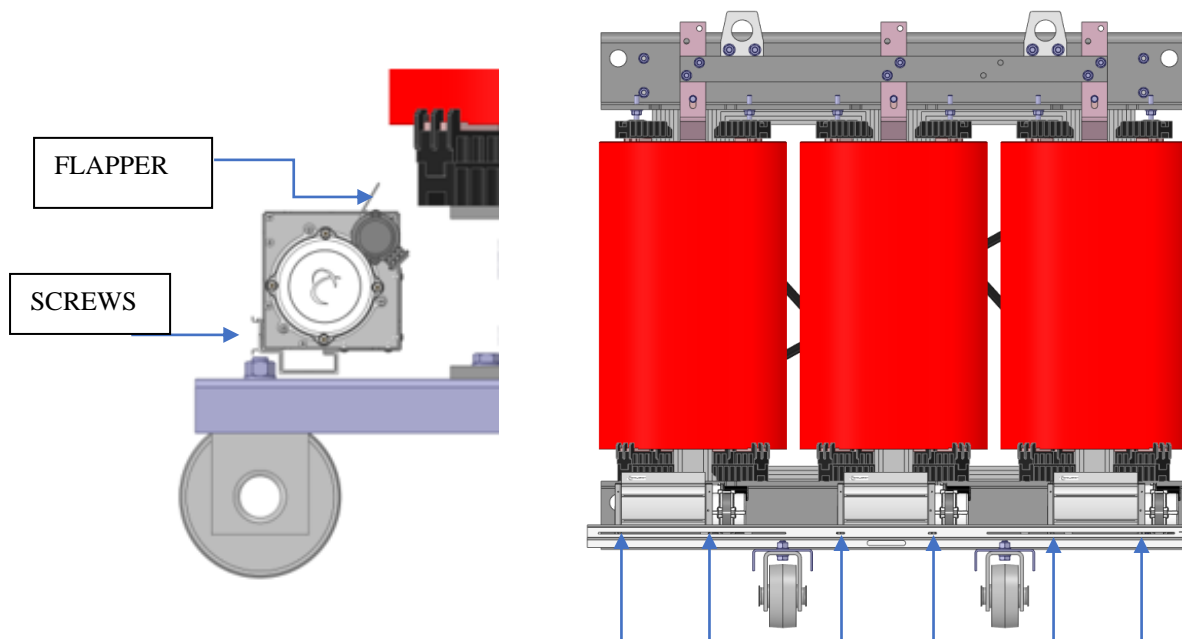

Use the special slots on both profiles and the self-drilling screws, supplied, to lock the fans in the desired position.

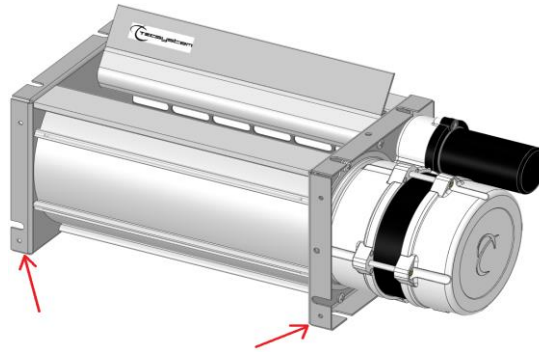

Use the fan flapper to correctly direct the air inside the transformer columns.

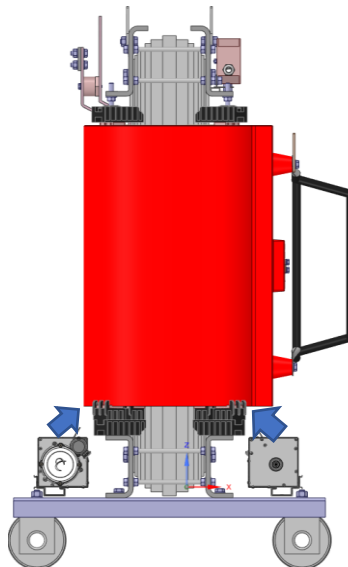

BAR WIRING

The bar has a recessed plug connector for powering the fans: M1-M2-M3 (*). By using the socket + case connector, it will be possible to connect the fans electrically, following the assembly procedure.

(*) the wiring with dedicated connector for the single fan is available on request.

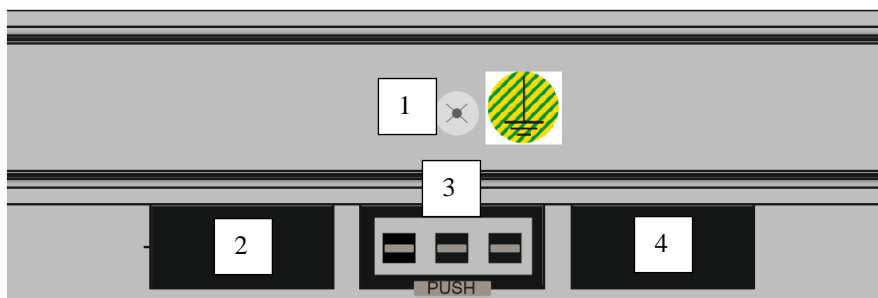

1)	Bar earth connection screw	3)	Power plug connector
2)	Closing Cap	4)	Closing Cap

BAR CONNECTOR

Assembling the socket connector + case following the instructions below.

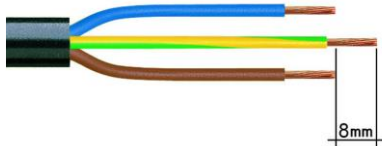

Strip the outer sheath of the multipolar cable (L-EARTH-N) to a length of 55mm. Strip the three conductors for 9mm. Keep the earth conductor with an increased length of 8mm.



Using a 2.5mm slotted screwdriver, press the internal spring of the connector. Insert the stripped conductor MAX 4mm, preferably with a dedicated ferrule, inside the reference terminal with the respective marking L-EARTH-N.

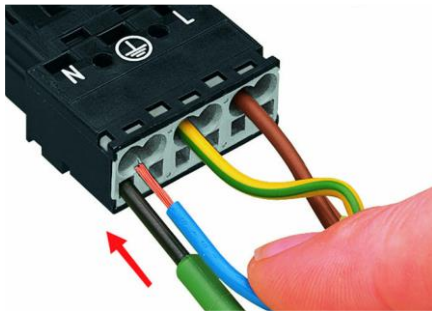

Terminate the connection by inserting the other L-EARTH-N conductors.

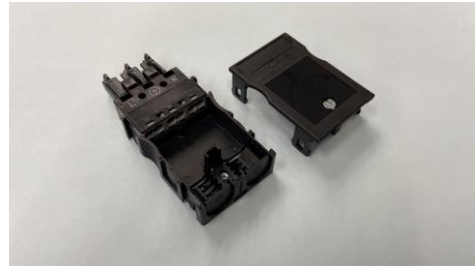

Put on the protective case supplied, and tighten the locking screw.

Insert the socket connector + assembled case (1) inside the plug connector (2) arranged on the bar.

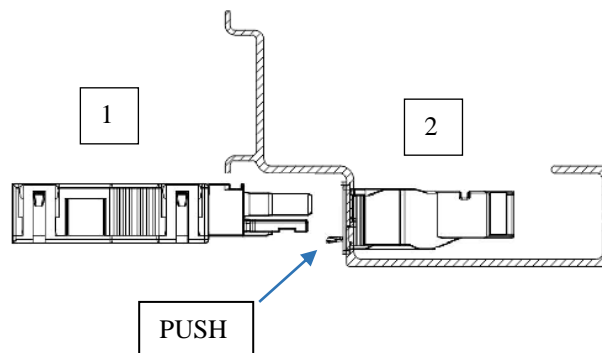

Use the push lever to connect and disconnect the fans' power supply. Make the connection indicated on both bars.

WYMIARY MONTAŻOWE SZYNY DO WENTYLATORÓW

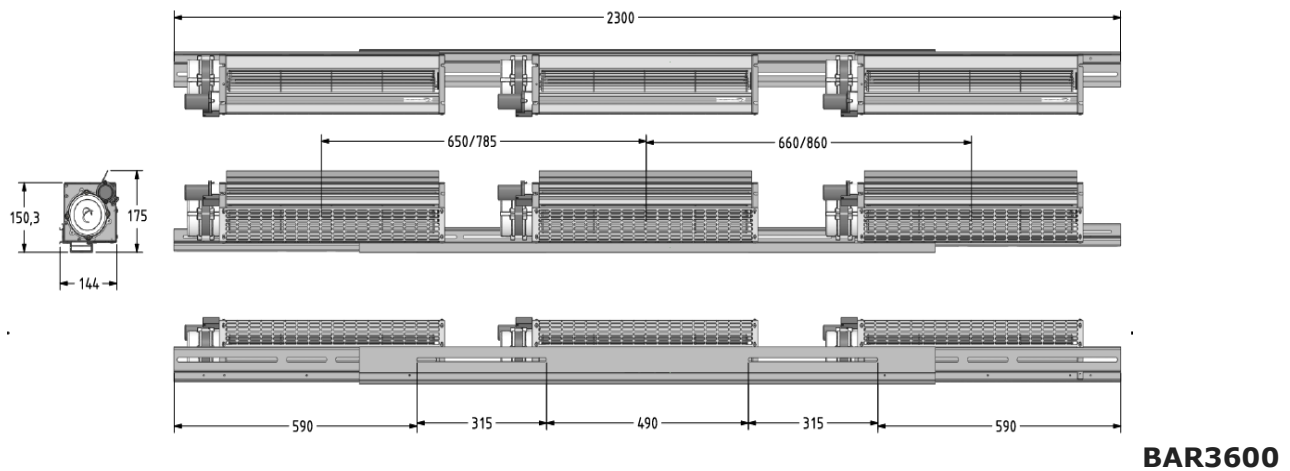
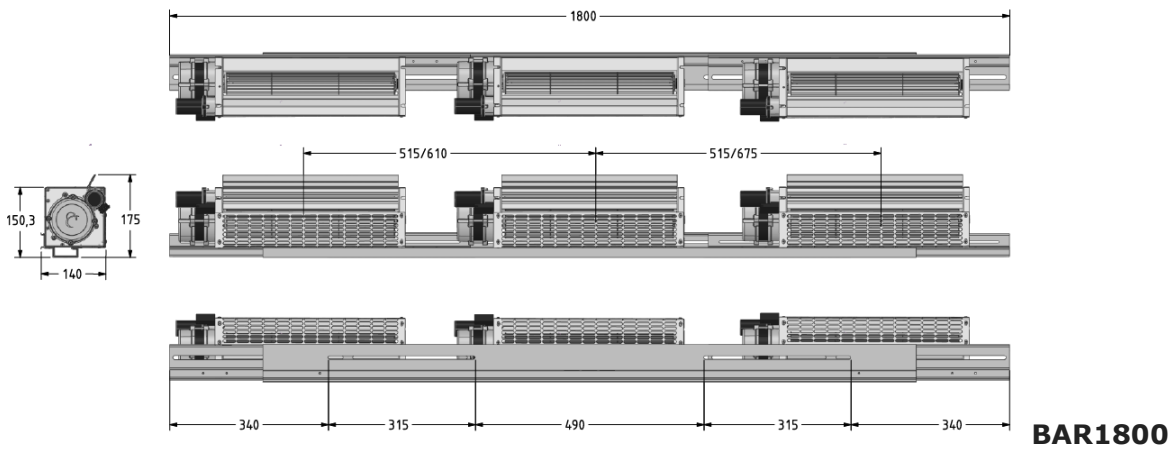
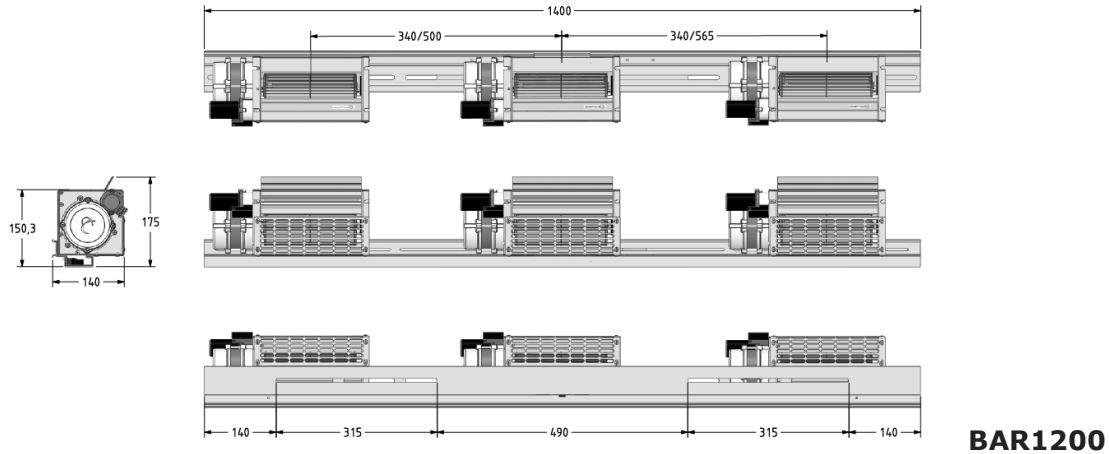

PROJEKTUJ NOWE WYZWANIA !!!!!
TECSYSTEM: SŁUCHA, REALIZUJE, PROPONUJE, PROJEKTUJE



TECSYSTEM

SUPPORTS YOU!

